

# Mini-Circuits®

## Most Often Asked Questions

---

***Q. Can you explain, briefly, how a DBM works as a phase detector?***

**A.** When a DBM is used as a phase detector, this is merely a special case of mixing action where the LO and RF signals are at the same frequency. Now, let's look at the mixer equation:

$$\begin{aligned} \text{IF output} &= A_1 \cos[(\omega_{LO} - \omega_{RF})t - (\theta_{LO} - \theta_{RF})] \\ &+ A_2 \cos[(\omega_{LO} + \omega_{RF})t - (\theta_{LO} + \theta_{RF})] \\ &+ [\text{higher order frequency terms}] \end{aligned}$$

In a phase detector application,  $\omega_{LO} = \omega_{RF}$ ; therefore in the first term,  $\omega_{LO} - \omega_{RF} = 0$  and thus the IF output is only a function of  $A_1 \cos(\theta_{RF} - \theta_{LO}) + A_2 \cos(2\omega t) + \text{higher frequency terms}$ .

With proper filtering, the  $2\omega t$  terms and higher can be eliminated so the IF output is equal to  $A_1 \cos(\theta_{RF} - \theta_{LO})$ .

Specifications of a DBM that are important in a phase detector application include:

- (1) DC offset,
- (2) maximum DC output,
- (3) isolation between ports,
- (4) polarity of output voltage,
- (5) frequency response,
- (6) temperature variation of DC offset.

***Q. How is DC offset affected by temperature?***

**A.** If only one input is present, say LO, there should be zero output. However, due to slight mismatch in the diodes and imperfect balance in the transformer windings, a small DC voltage will appear at the IF output. This is called the DC offset voltage.

The value of the DC offset varies with temperature. Over a wide temperature range, say from -55 to +100° C, the unbalance of the mixer diodes will have a major influence on the DC offset with only a slight contribution from the transformer.

An effective technique to minimize DC offset variation with temperature is to use diodes whose characteristics track with temperature. This can be accomplished by using diodes manufactured from the same wafer in the same production lot. At Mini Circuits, this selection technique is used exclusively in the production of mixers. Also Mini-Circuits employs specially-designed winding machines so that the assembled transformers have well-matched windings.

The net result-Mini-Circuits offers ultra-low DC offset characteristics; less than 300 to 400  $\mu$  V over a -55 to 100° C temperature range.0

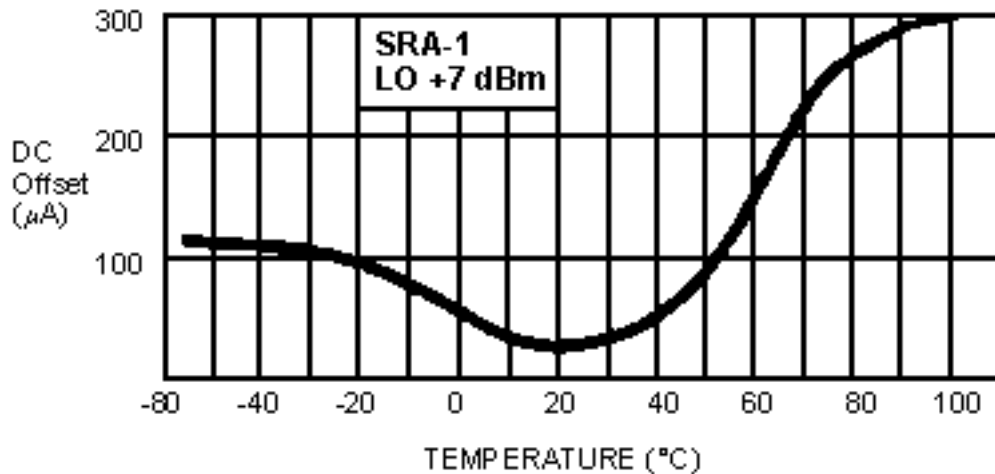

**DC Offset Temperature Characteristics**

**Q. Why is DC offset so important?**

**A.** In many phase detector applications, one of the two signals may be 90° out of phase with the other. Theoretically, the phase detector output would be zero. However, there will be a slight DC output due to the offset voltage. This would then be interpreted as a phase difference of other than 90°. Thus, the lower the DC offset voltage, the more accurately the phase detector performs its function.

**Q. Suppose the DC output of a DBM phase detector is insufficient for my application. What do you suggest?**

**A.** Use a higher level mixer than you had selected. Or specify one of Mini-Circuits RPD series of high "figure-of-merit" phase detectors. Or use an op amp.

**Q. I want to compare the phase of two square waves. Do I have to convert them to sine waves before applying them to a phase detector?**

**A.** No. Since the phase detector operates in a saturated mode and tends to square up a sine wave, it is not necessary to alter the square wave inputs.

**Q. Is there any difference in the frequency range spec when a DBM is used as a phase detector?**

**A.** Yes. The frequency specs for RF apply to a DBM operating in an unsaturated mode. When used as a phase detector, the DBM is operating in a saturated mode, which tends to shrink the bandwidth. Thus, to be conservative when using a DBM as a phase detector, select a mixer with a bandwidth 1.5 times wider than the unsaturated specs. For example, if your phase detector application covers 1-500 MHz, select a mixer whose RF port specification is at least 0.66-750 MHz.

**Q. Isolation specs for LO to RF and LO to IF are generally included in mixer specs, but RF to IF**

*isolation is often not listed. What are typical values?*

**A.** In a mixer application, the RF signal level is generally very low and thus the RF-IF isolation parameter is unimportant. However, in a phase detector application, the RF level is high and thus the RF-IF isolation becomes important. As a rule of thumb, LO-IF isolation is generally less than LO-RF isolation - 10 dB less at low frequency, 15-20 dB less at mid- and high-frequency.

*Q. I intend to use an op amp following the phase detector. What potential problems do I face?*

**A.** There are three potential problems. First, although the op amp theoretically will have zero DC volts at its input, it will actually have some small DC voltage; thus when the op amp is connected to the phase detector, this voltage will cause an unbalance in the phase detector diode circuit. Second, the op amp exhibits a high impedance while the phase detector offers 50 ohm impedance, posing a serious mismatch. Finally, it is necessary to filter out the sum frequency components created by the mixing action of the DBM acting as a phase detector.

A solution to remedy these problems involves a simple RC filter as shown. Since the op amp has a very high input impedance. The 1K series resistor does not attenuate the DC output from the phase detector. Also any small DC voltage at the op amp is attenuated by 20:01 (by the 1K and 51-ohm resistor combination) at the phase detector output. The RC combination acts as a low pass-filter to attenuate the sum frequencies; if additional filtering is required, a multiple-section RC filter can be used.

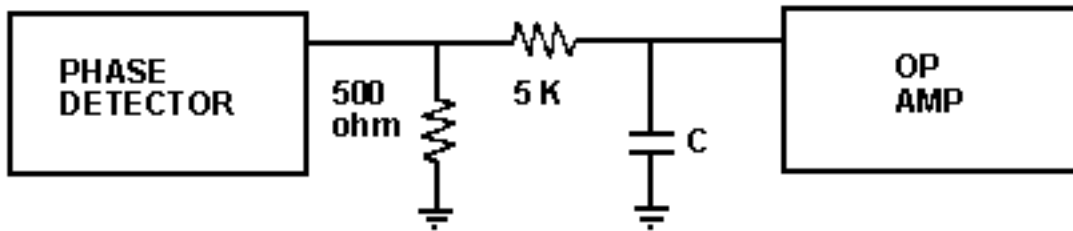

*Filtering the Phase Detector Output*

*Q. Is it necessary to provide a filter at the output of the phase detector?*

**A.** In many cases, yes, the  $RF_1$  and  $RF_2$  term ( $w_1 + w_2$ ) must be removed since it may cause system degradation. The frequency terms in the IF output can leak into the system and cause amplifier saturation or other seemingly unexplained results.

*Q. What are the basic steps to select the proper phase detector?*

**A.** First, decide on the maximum DC output needed. Next, select a phase detector with adequate bandwidth. Then decide on the required isolation and make sure the detector you select meets the requirement.

Finally, if phase accuracy is critical, specify the maximum DC offset tolerable for the intended frequency range and, at your request, Mini-Circuits will test and screen to insure this requirement is met at minimal or no charge.

***Q. What is the performance characteristic of a phase detector?***

**A.** The phase detector performance curve displays the variation of DC output at the IF port with phase difference between the RF inputs at the Reference and RF ports. The performance curve is sinusoidal for a double-balanced mixer, DBM, used as a phase detector.

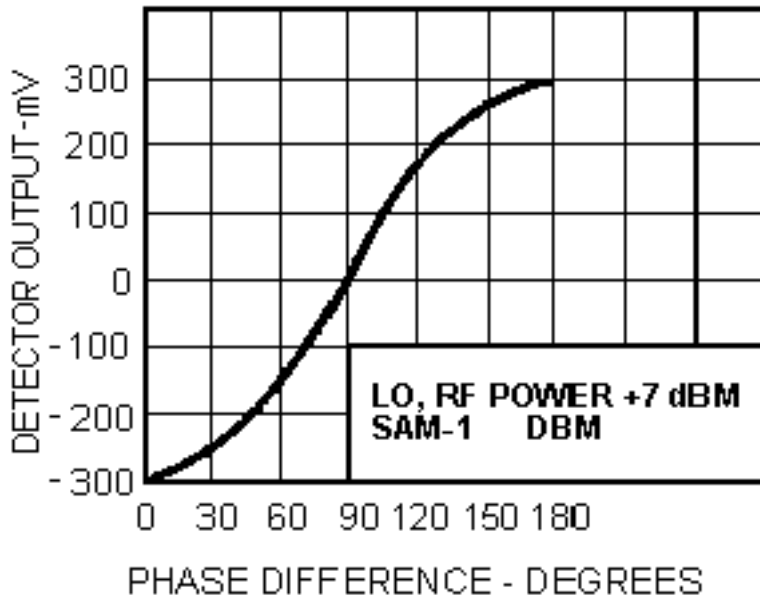

***Phase Detector Performance Curve***

***Q. Is the DC polarity output of a phase detector fixed by the manufacturer or can the polarity be reverse at the user's discretion?***

**A.** When the signals are in phase, Mini-Circuits detectors are manufactured to provide a negative output, see schematic shown. If the user requires a positive DC output, he would merely reverse the connections at the reference port; for positive DC output, pin 8 is grounded with the reference input applied to pin 7.

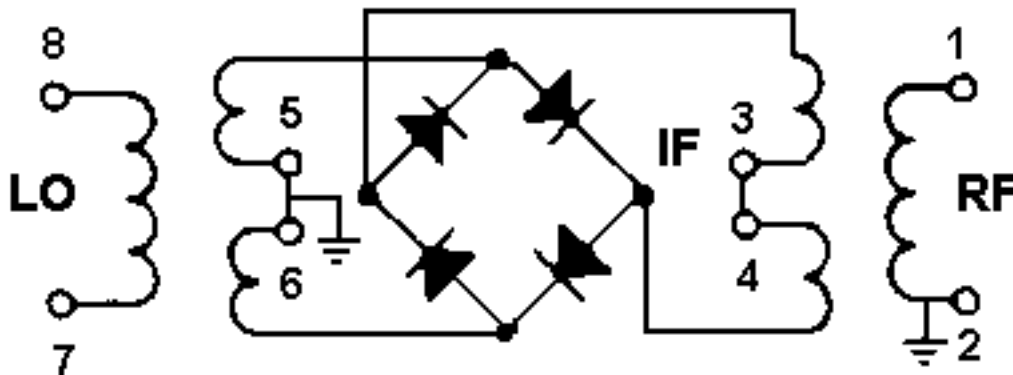

***Phase Detector Schematic***